

Pack

Contenuto confezione
 Package contents
 Contenu de l'emballage
 Packungsinhalt
 Contenido del paquete

E044196

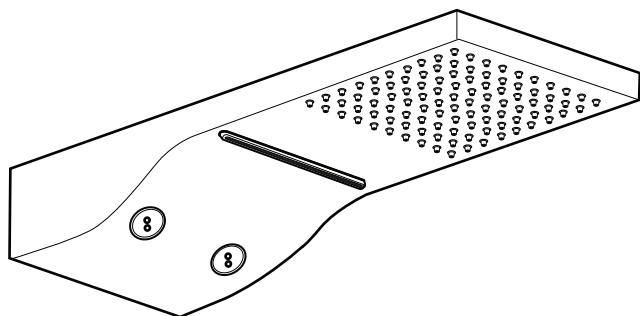

X1

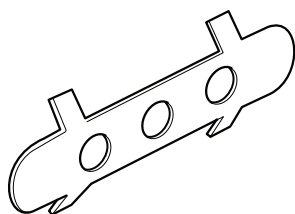

X1



X2

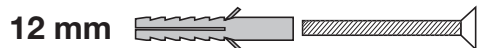

X4

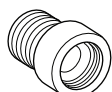

X3

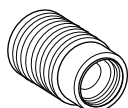

X3



X3

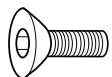

X4

IT Istruzioni di montaggio
 GB Mounting instructions
 FR Instructions de montage
 DE Montageanweisungen
 ES Instrucciones de montaje



X1

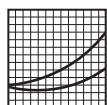

IT Diagramma di flusso
 GB Flow rate
 FR Le débit
 DE Flussdiagramm
 ES Diagrama de caudal



IT Indossare protezioni
 GB Wear protection
 FR Porter une protection
 DE Schütze anziehen
 ES Usar protección

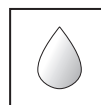

IT Caratteristiche idrauliche
 GB Plumbing specifications
 FR Caracteristiques hydrauliques
 DE Hydarulische Eigenschaften
 ES Características hidráulicas



IT Pressione d'uso
 GB Operating pressure
 FR Pression d'utilisation
 DE Betriebsdruck
 ES Presión de uso



IT Temperatura dell'acqua
 GB Water temperature
 FR Température de l'eau
 DE Wassertemperatur
 ES Temperatura del agua

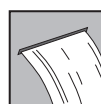

IT Litri d'acqua al minuto
 GB Liters of water per minute
 FR Litres d'eau par minute
 DE Liter Wasser pro Minute
 ES Litros de agua por minuto

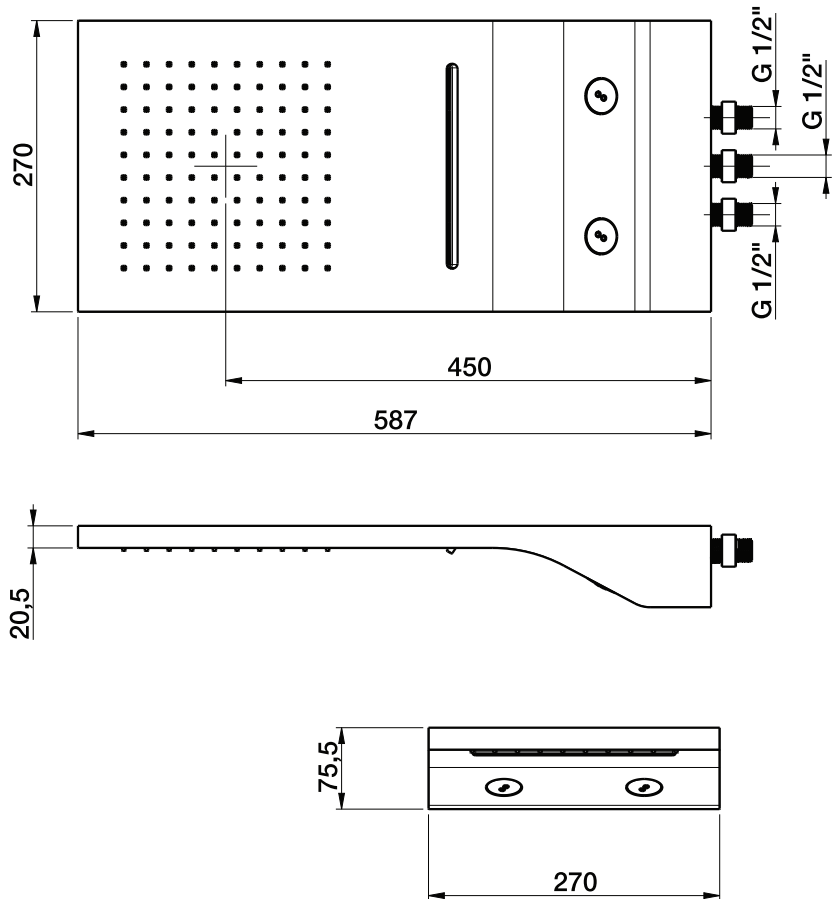
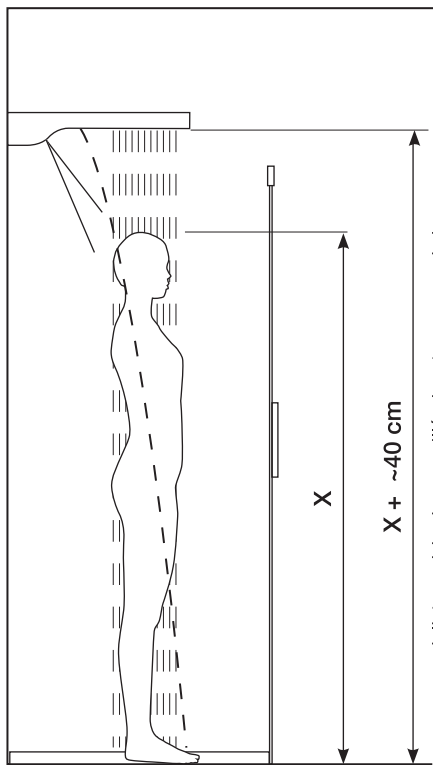

FALL | **IT** | Portata l/m cascata
GB | l/m waterfall flow
FR | Débit l/m cascade
DE | l/m Wasserfallfluss
ES | Caudal l/m cascada



RAIN | **IT** | Portata l/min. pioggia
GB | l/min. rain flow
FR | Débit l/min. pluie
DE | l/min. Regenfluss
ES | Caudal l/min. lluvia



SPIN | **IT** | Portata l/m getto rotante
GB | L/m spin flow
FR | Débit l/m tournoisement
DE | L/m Drehfluss
ES | Caudal l/m flujo rotatorio

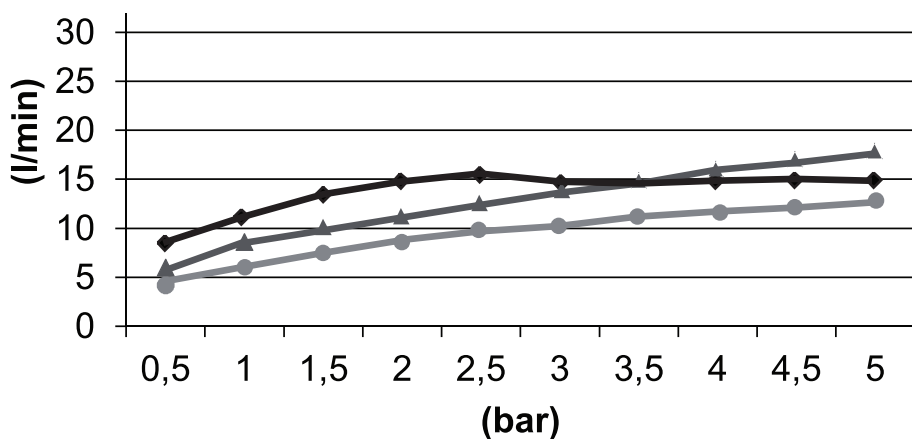



	MIN 1 Bar
	MAX 5 Bar
	BEST 3 Bar
	MAX 70° C
	BEST 38°/40° C

Tabella di Portata (Litri/min)

Bar	Pressione Dinamica (bar) / Portata (Litri/min)									
	0,5	1	1,5	2	2,5	3	3,5	4	4,5	5
FALL	7,5	11,2	13,3	14,8	15,2	14,8	14,9	14,9	14,9	15
RAIN	5	7,8	9,5	11	12,5	13,6	14,8	15,9	16,9	18
SPIN	4,2	5,9	7,1	8,3	9,2	10,1	10,9	11,7	12,4	13



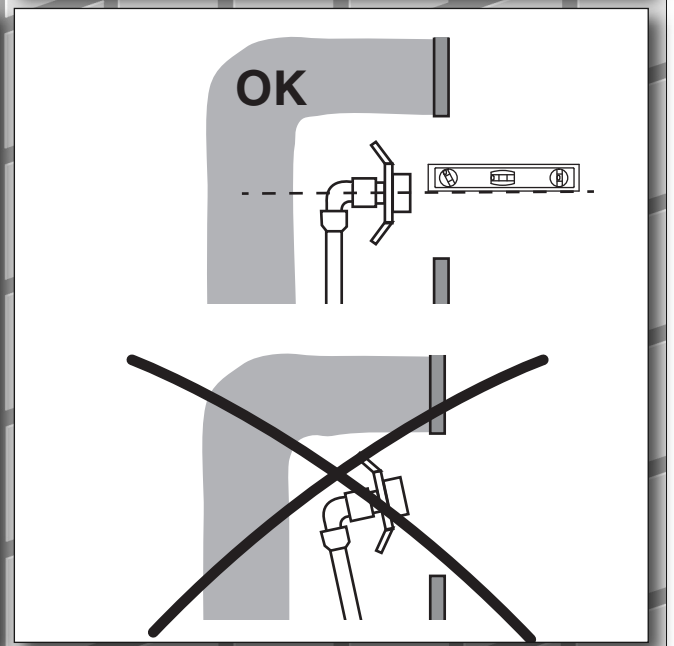
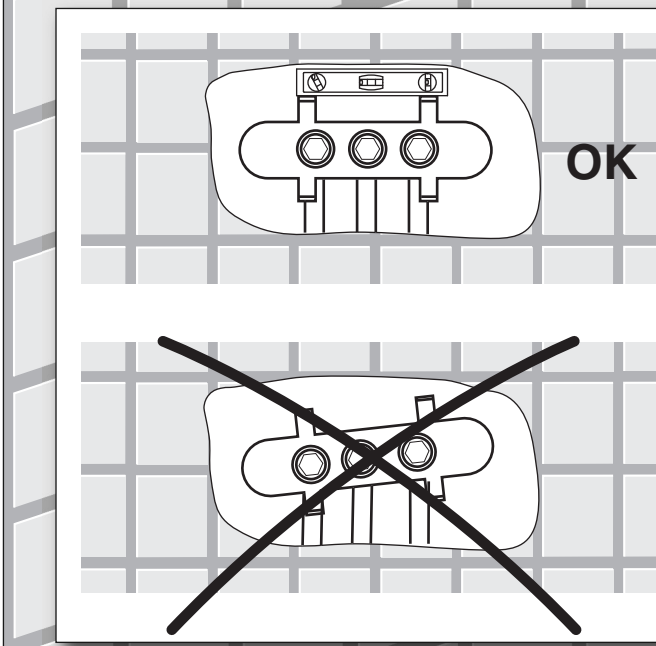
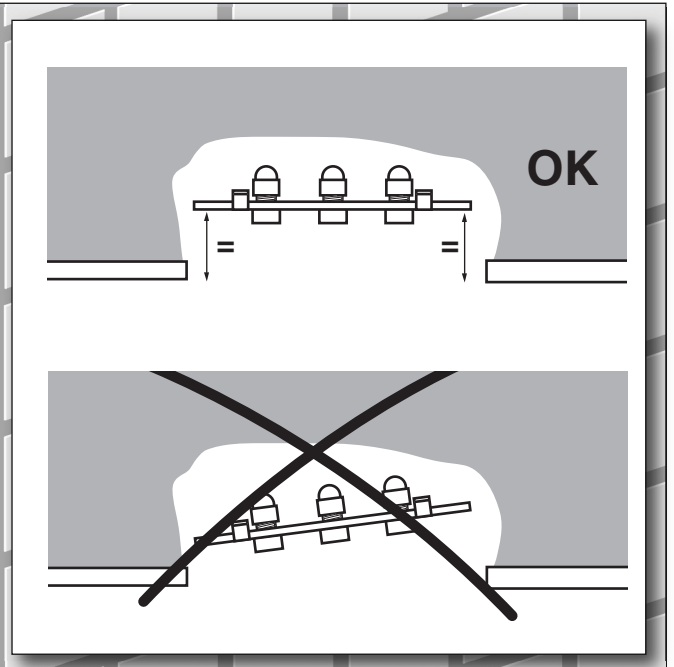
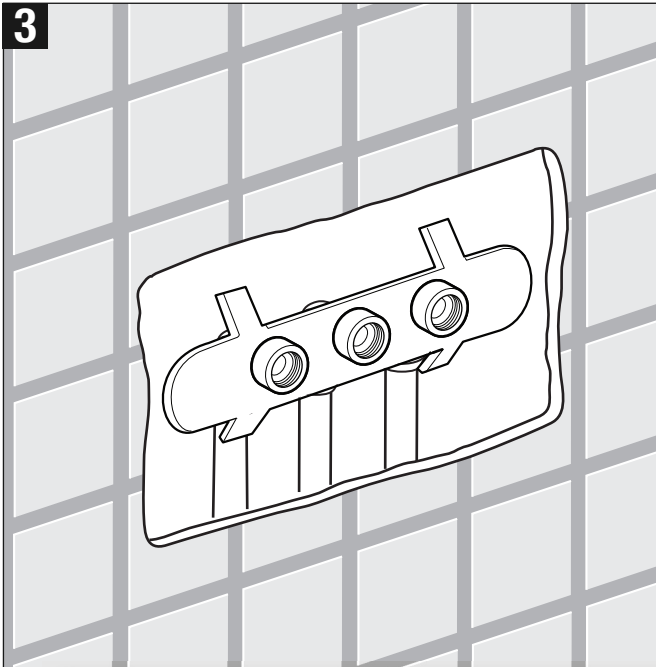
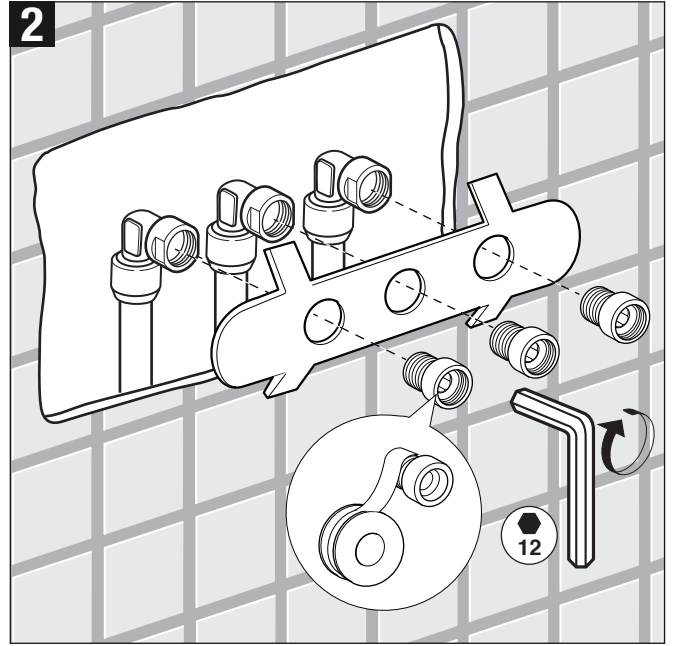
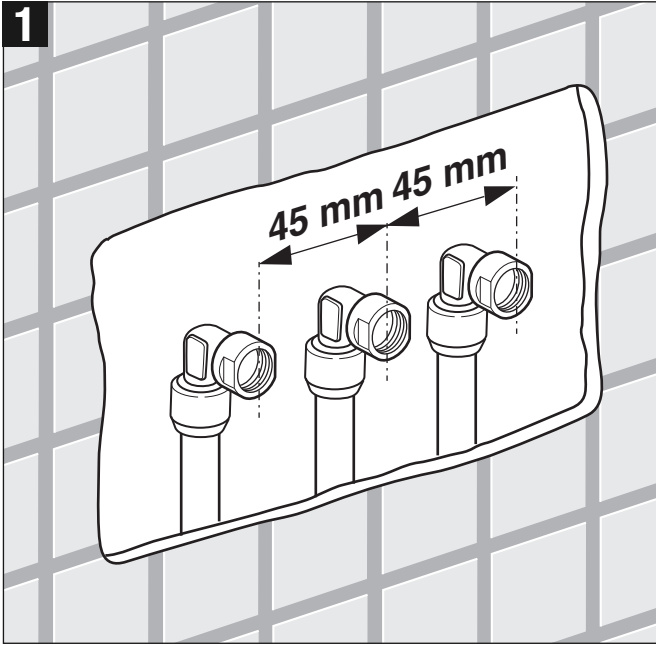
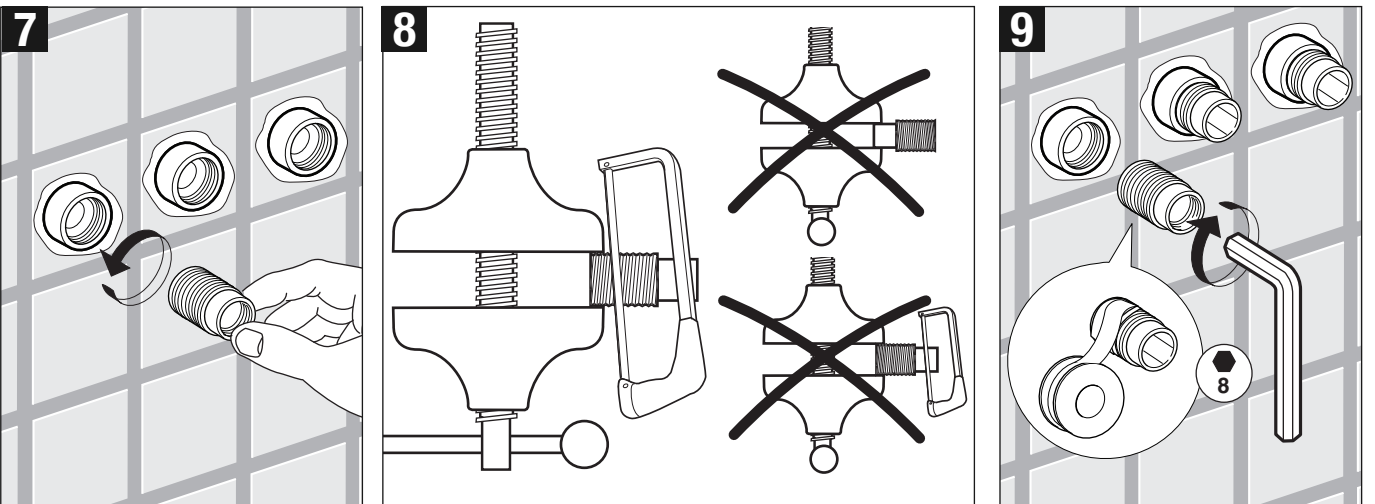
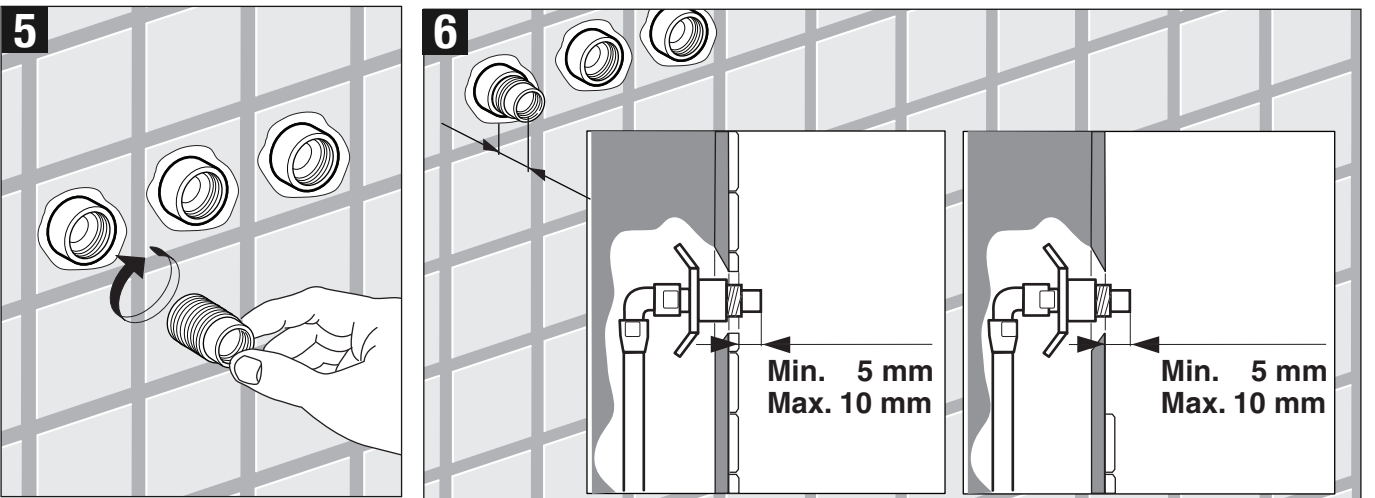
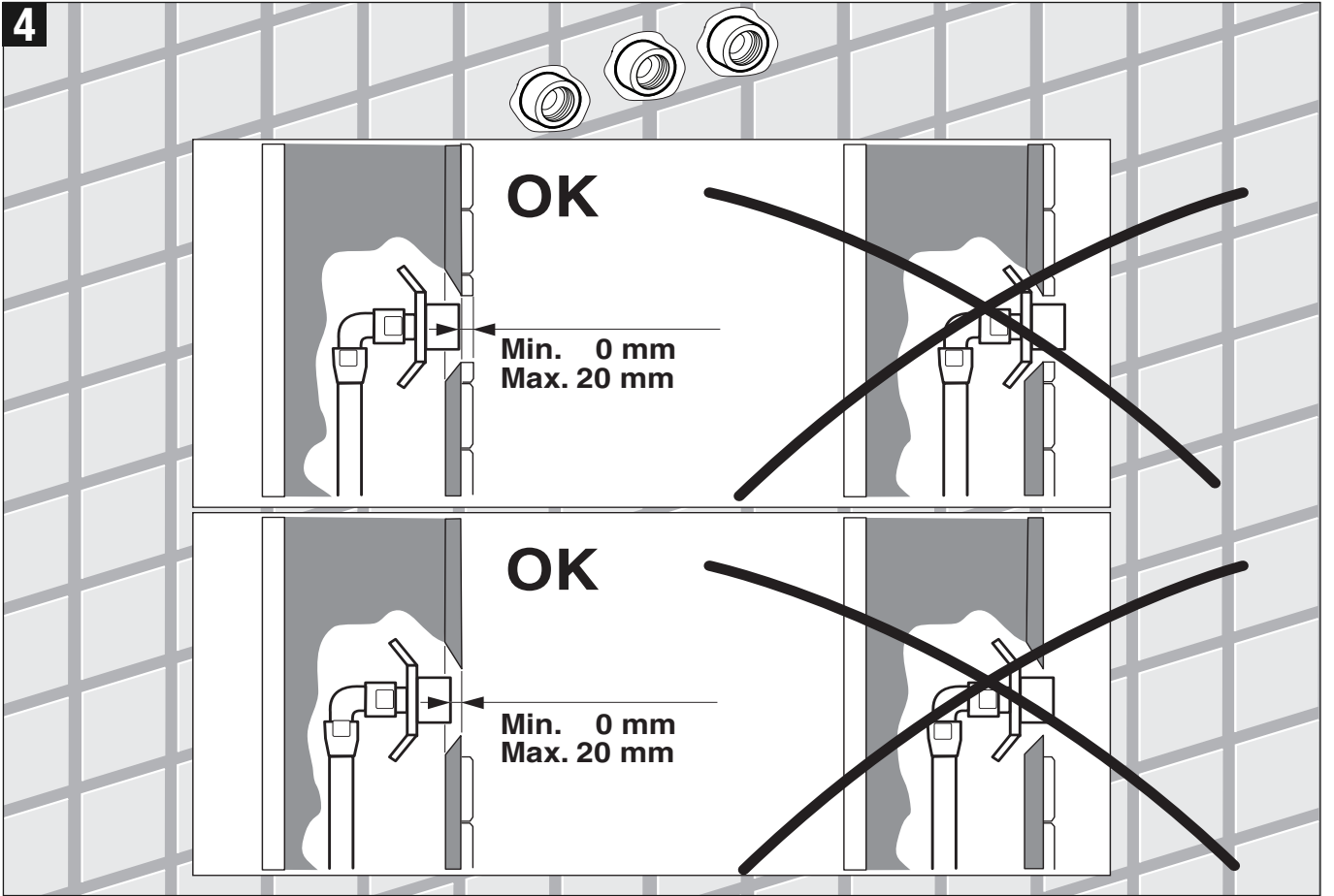

10

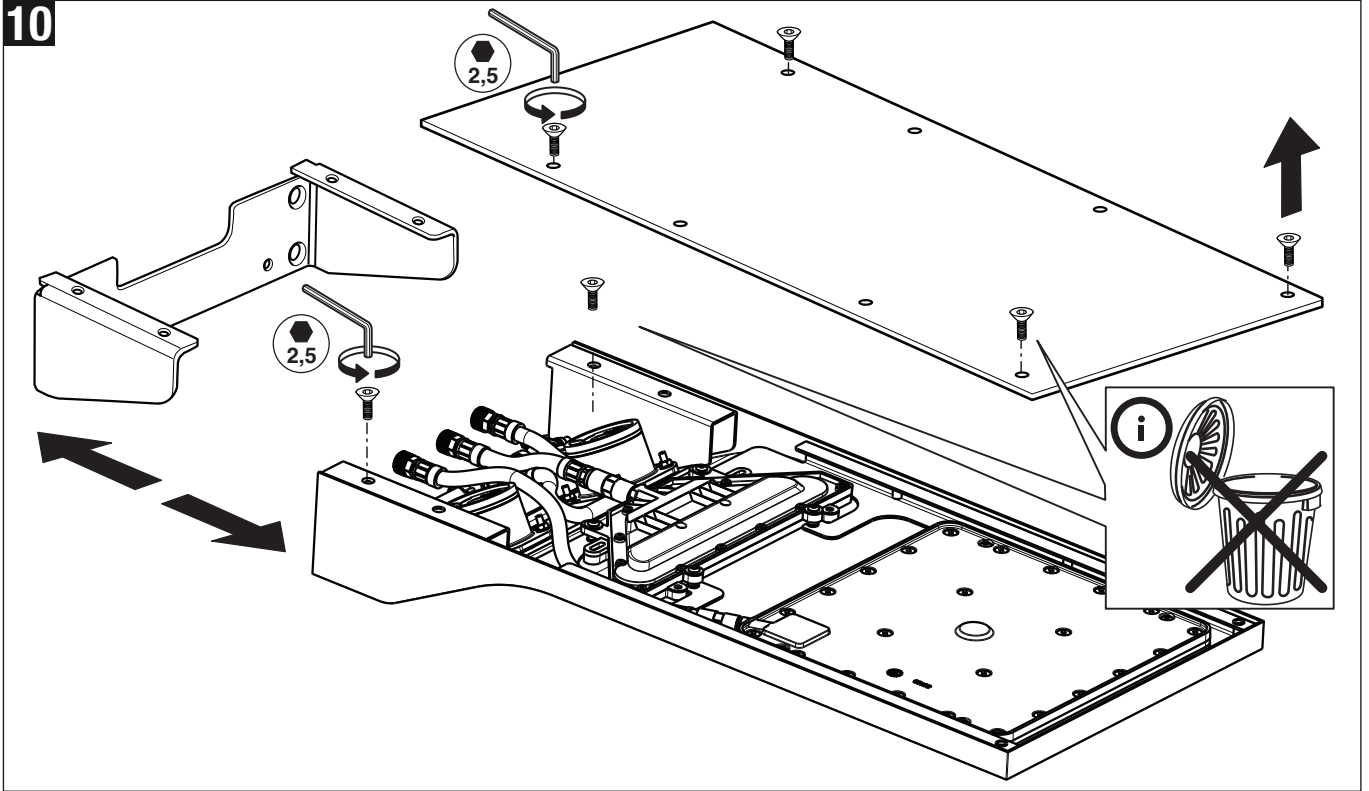

11

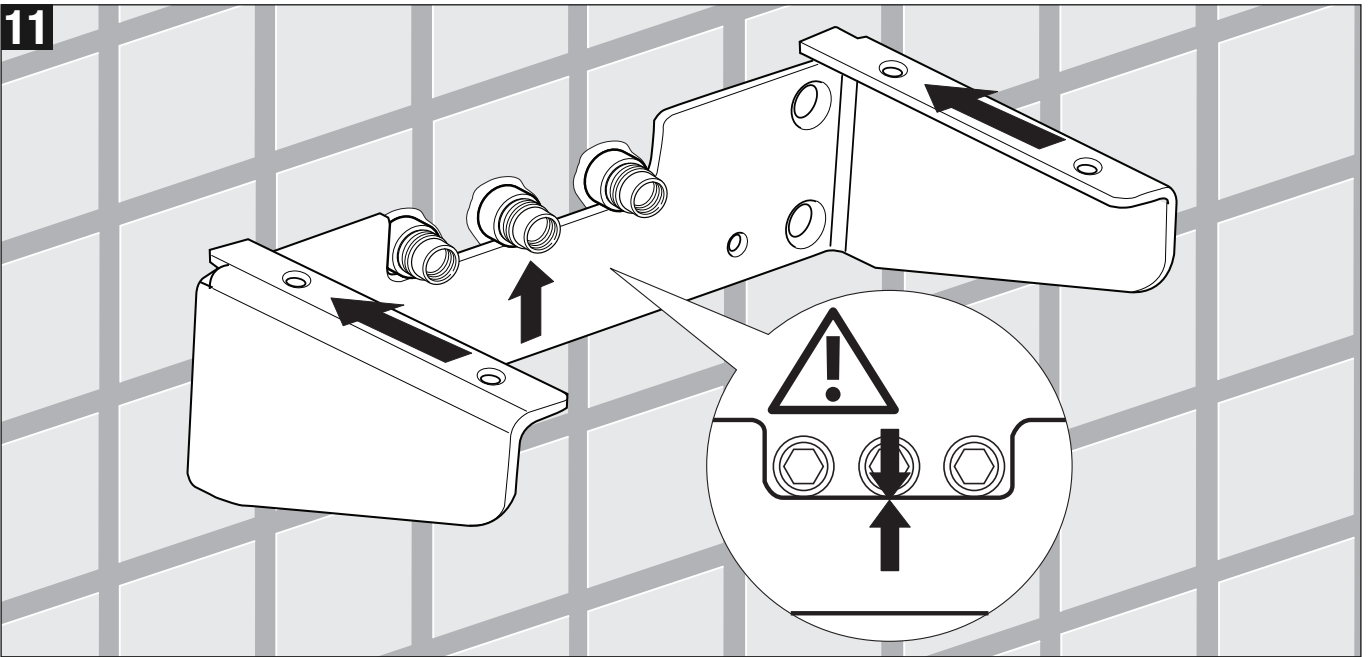

12

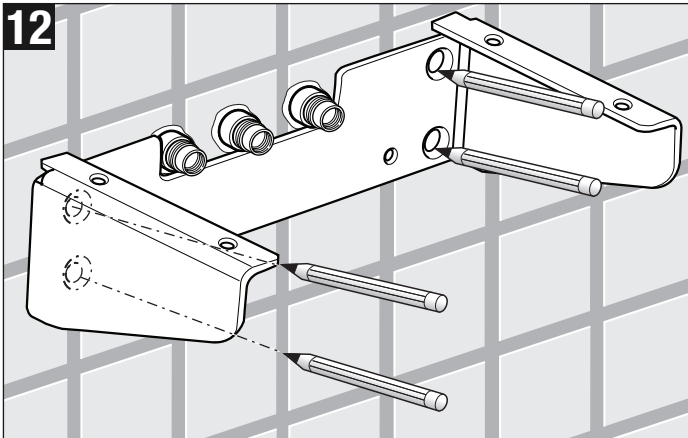

13

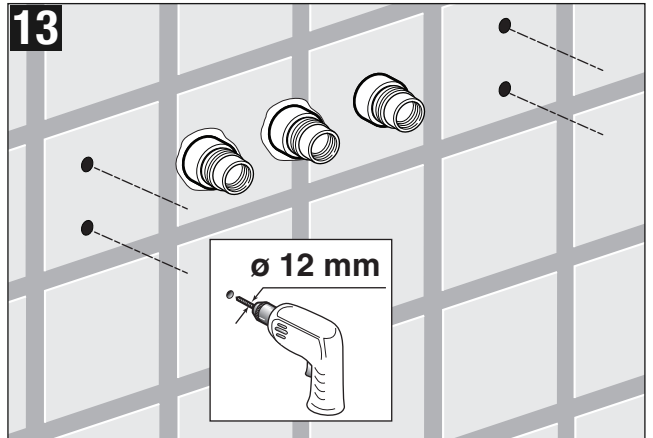

14

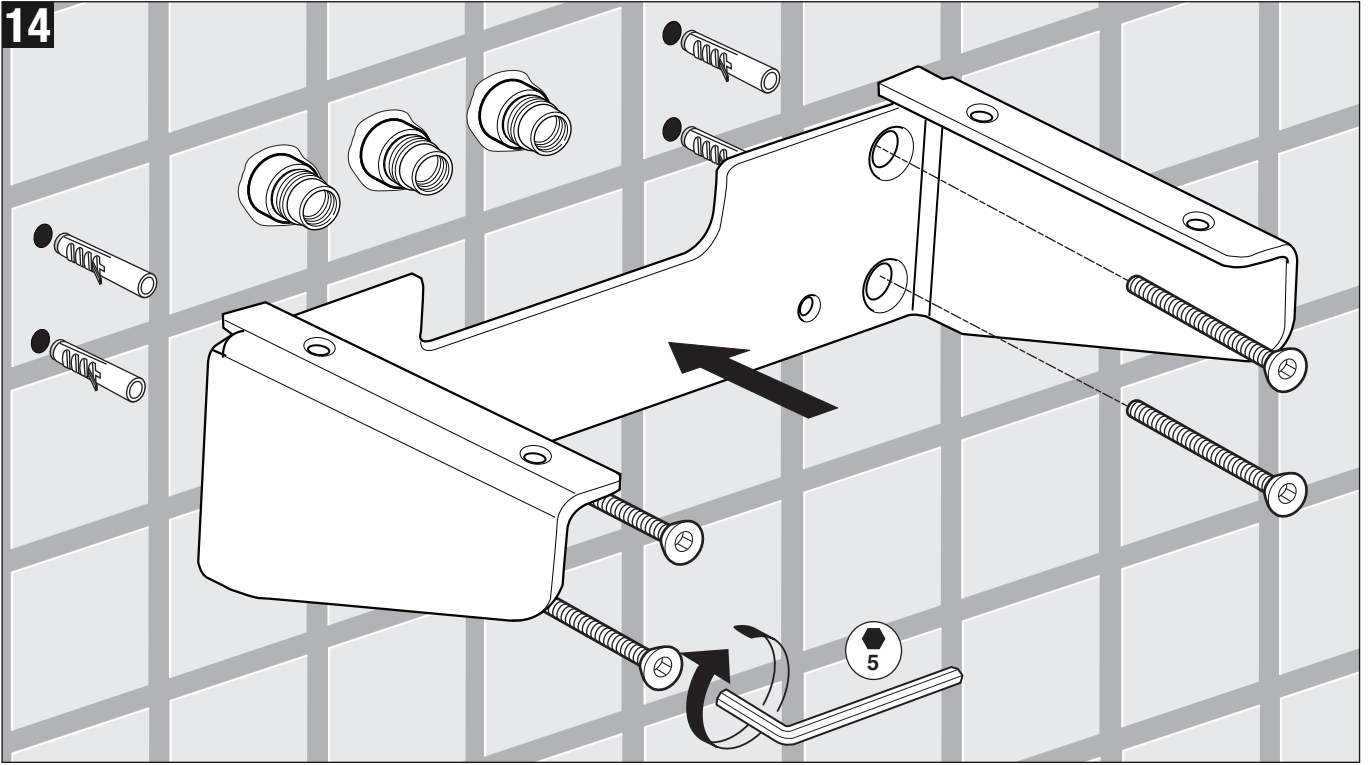

15

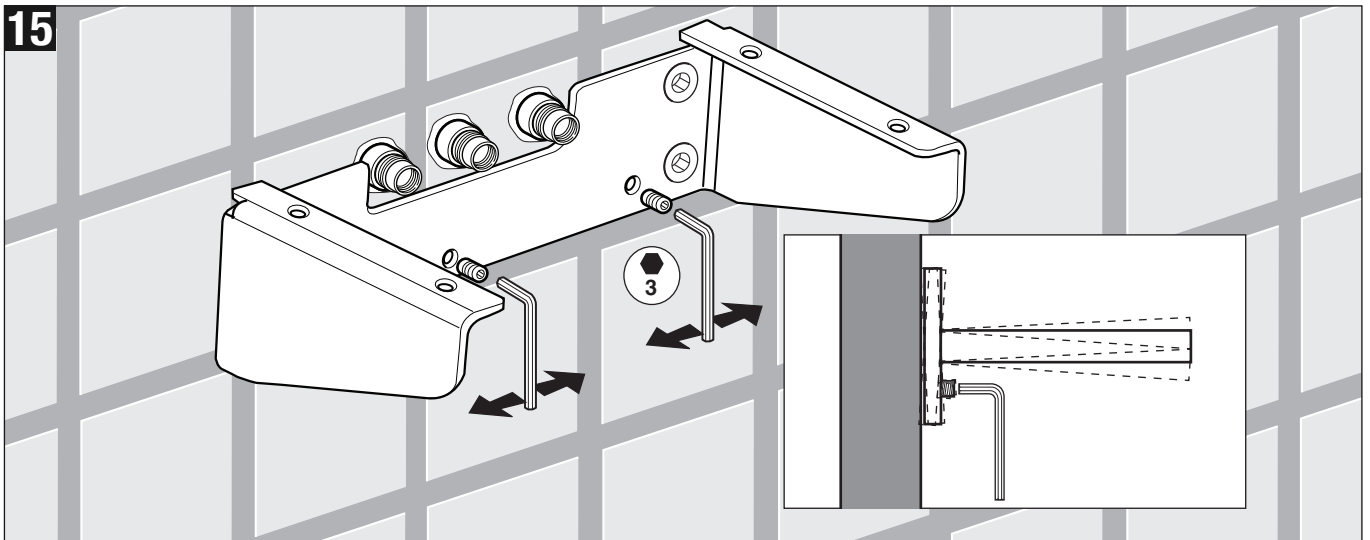

16



17

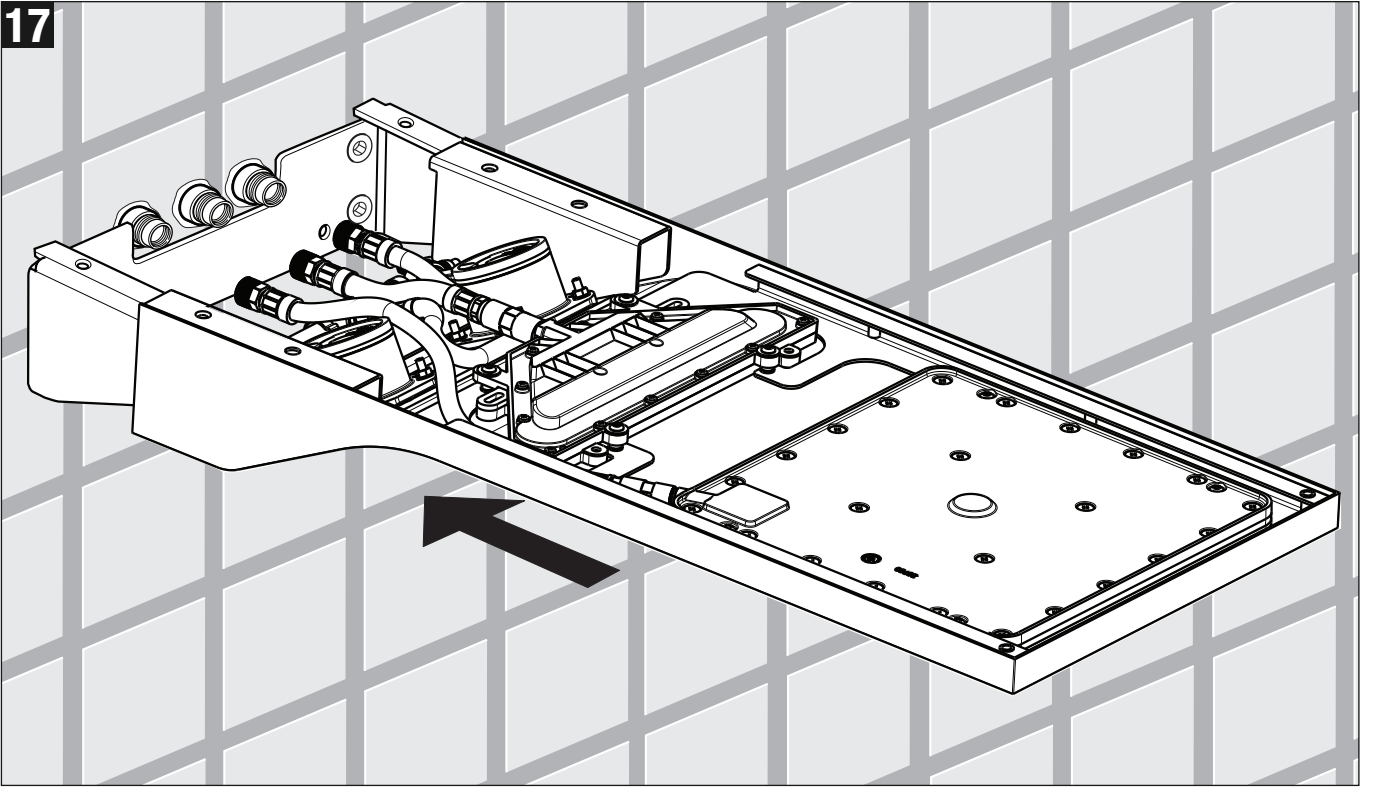

18

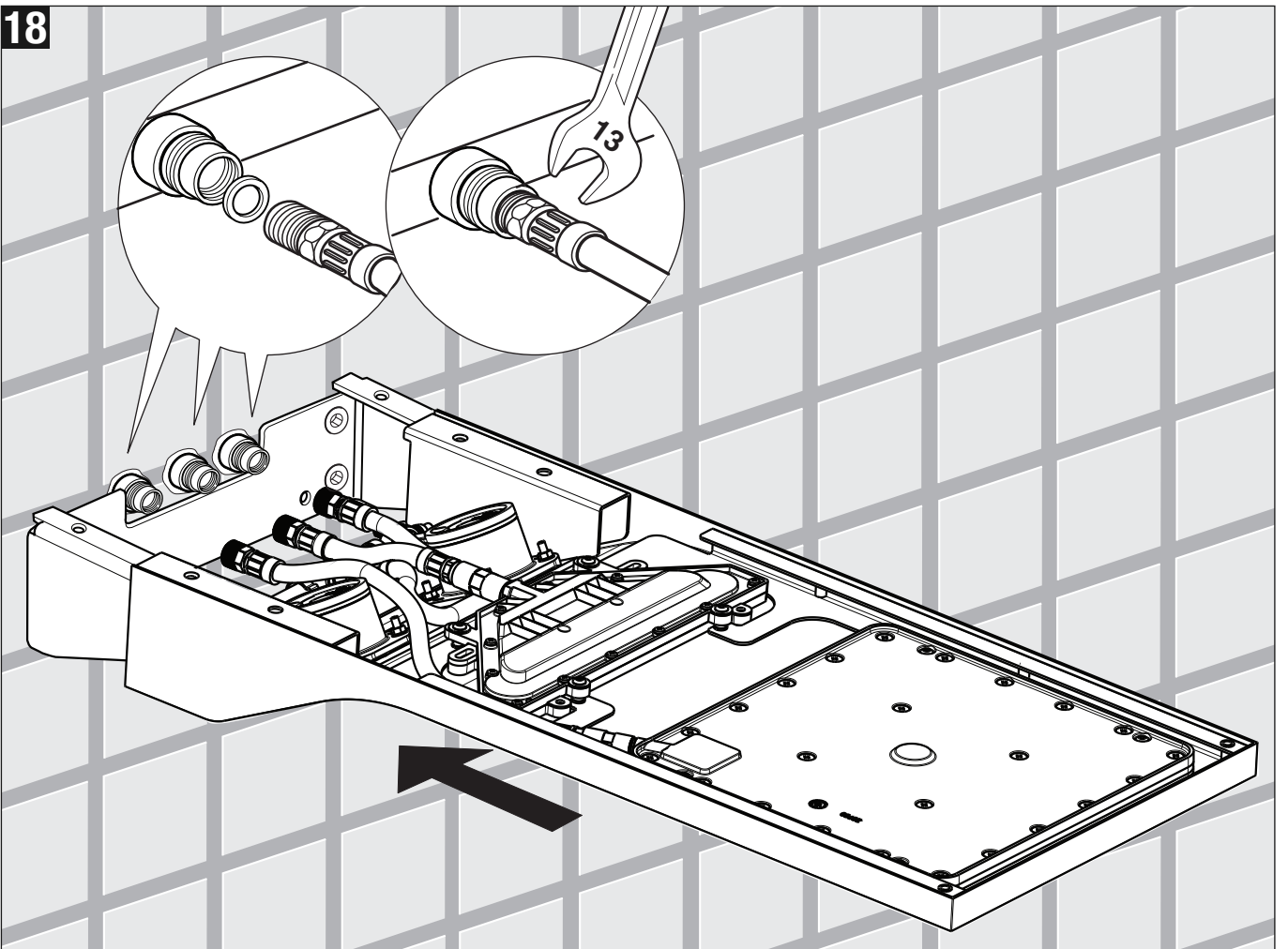

19

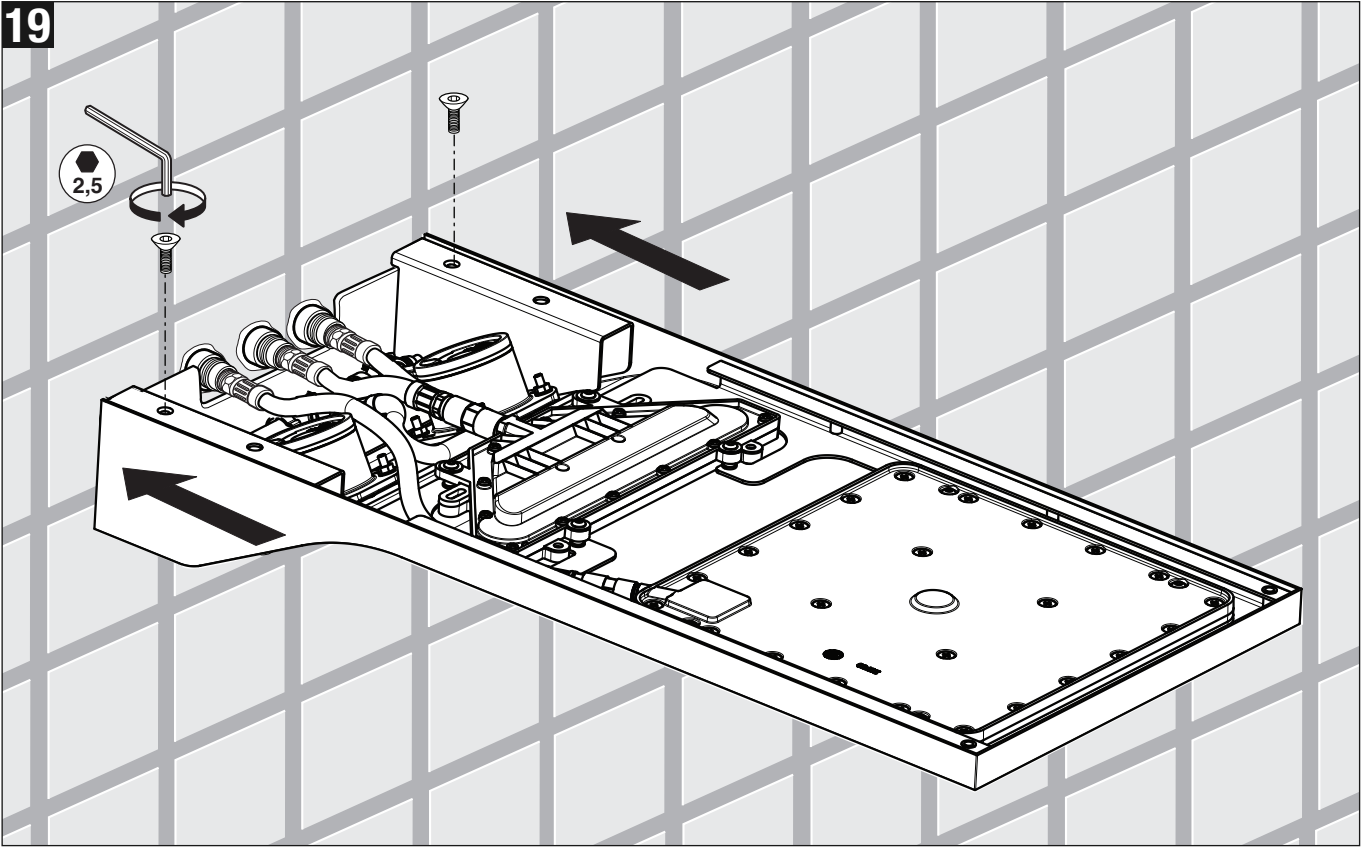

20

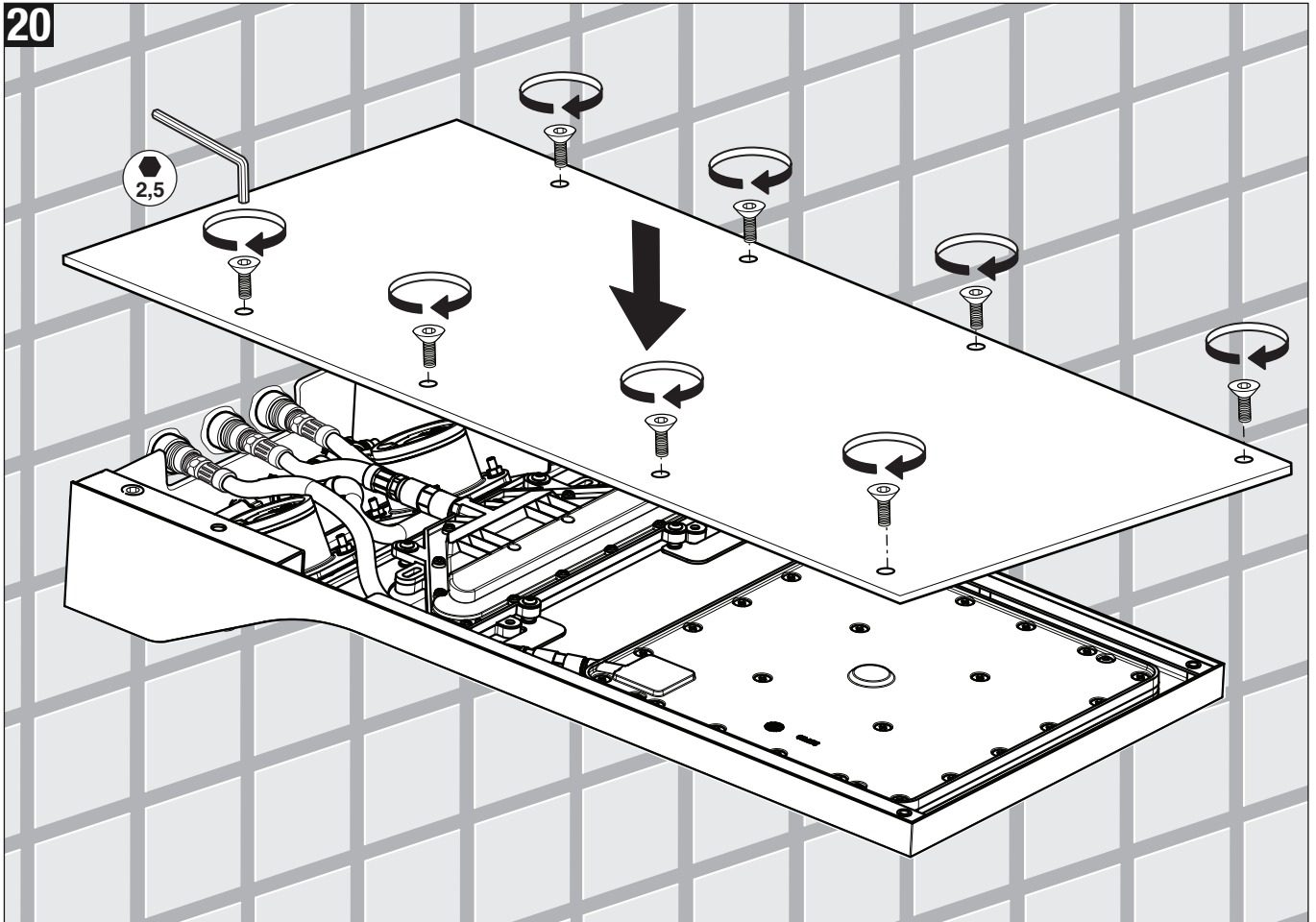

Cleaning

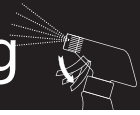

Suggerimenti per la pulizia
Cleaning Tips
Conseils de nettoyage
Reinigung Tipps
Consejos de limpieza

1

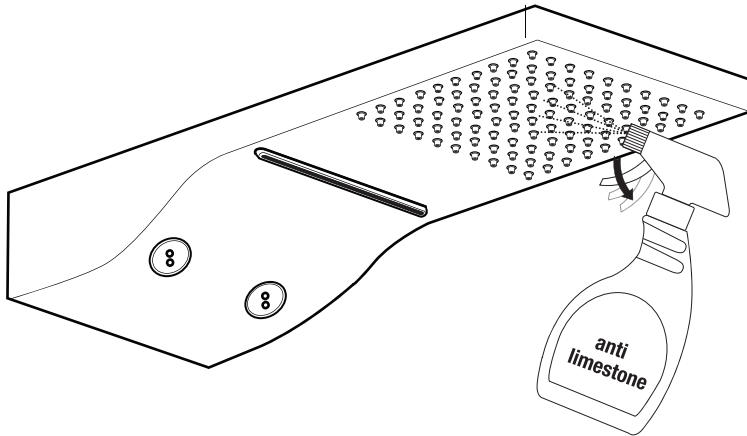

2

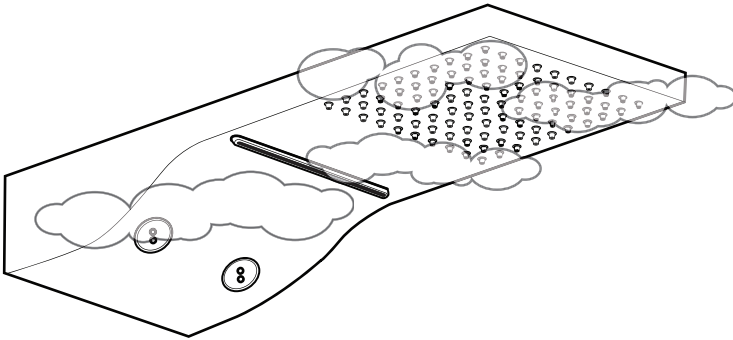

3

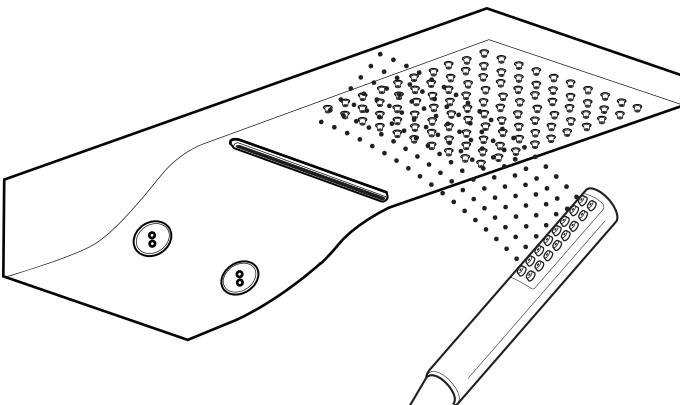

Calcare
Limestone
Calcaire
Kalkstein
Piedra caliza

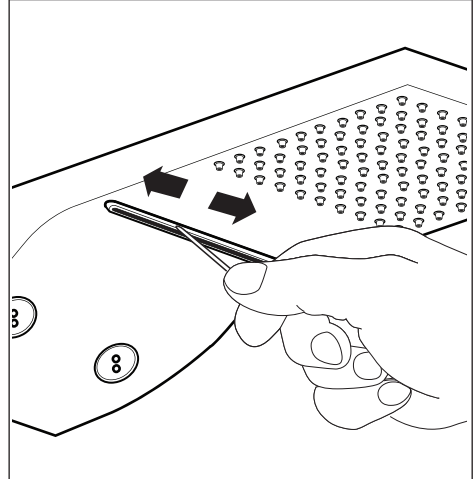
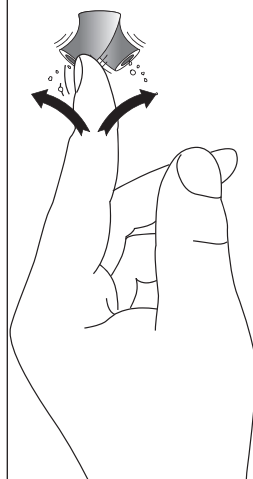
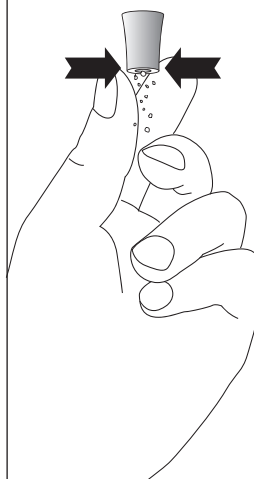
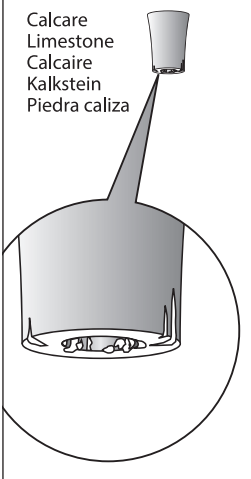

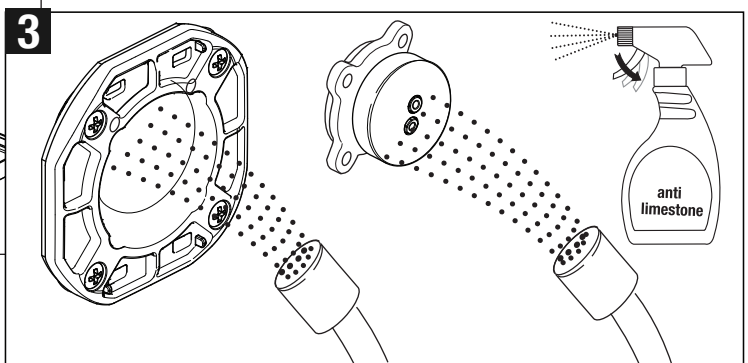
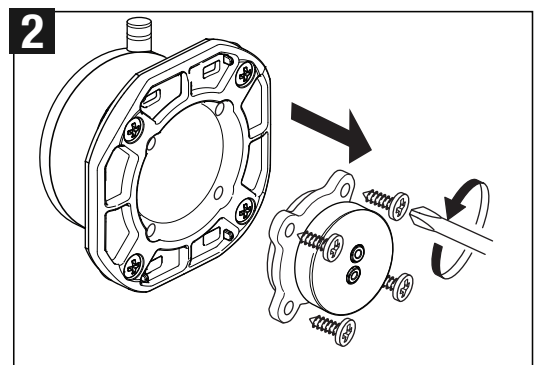
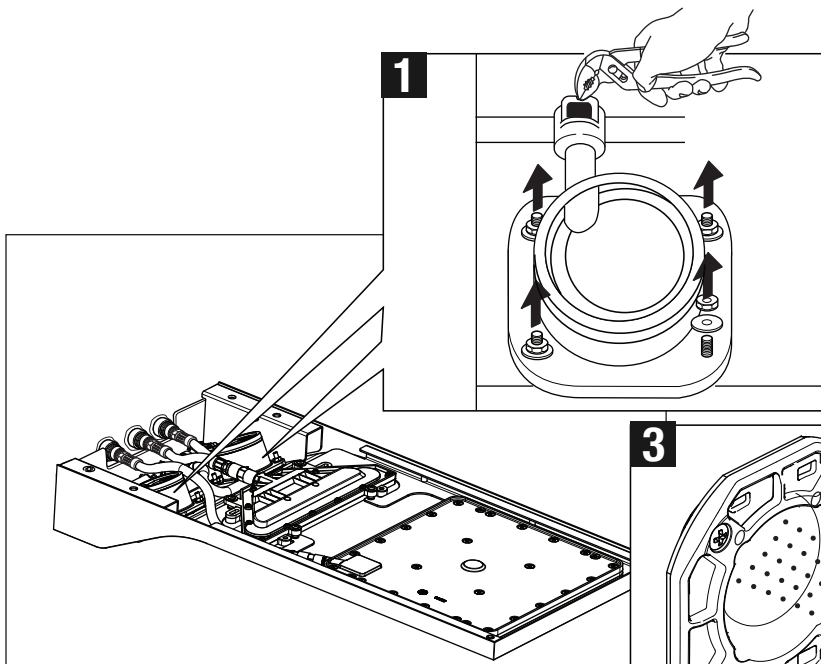
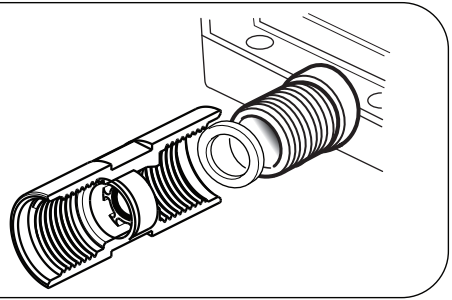
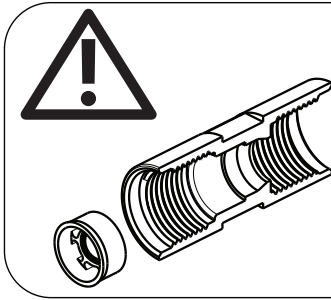
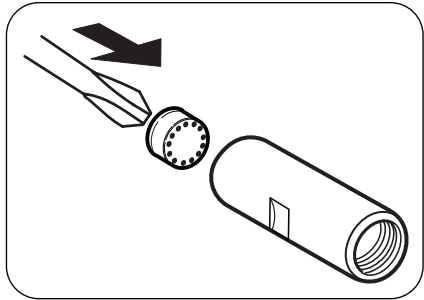
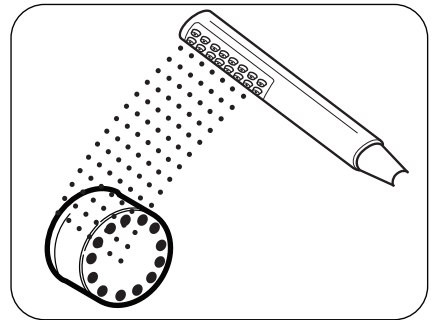
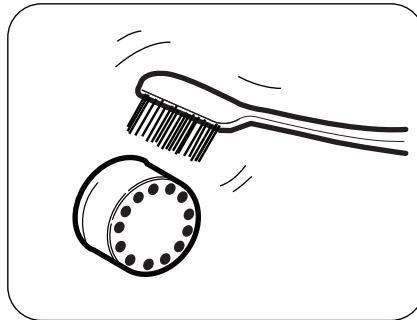
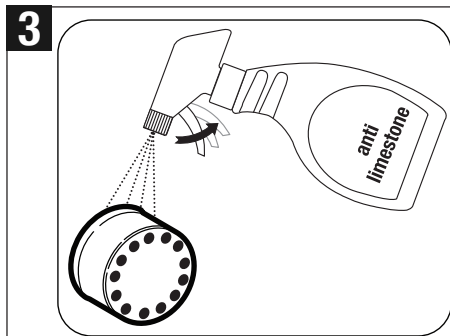
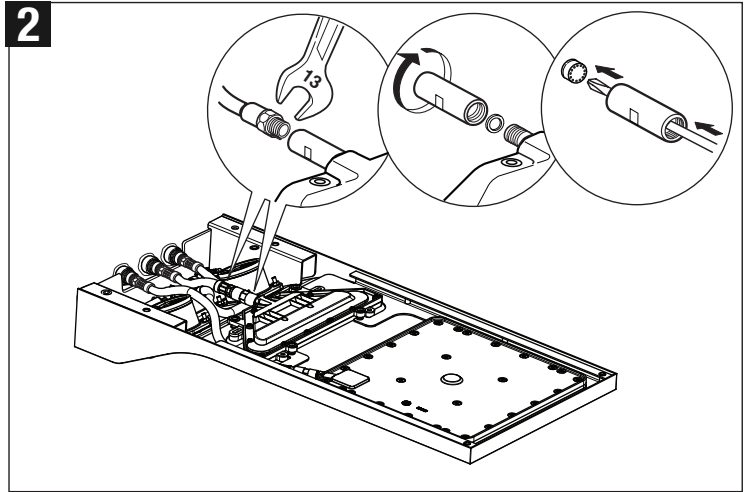
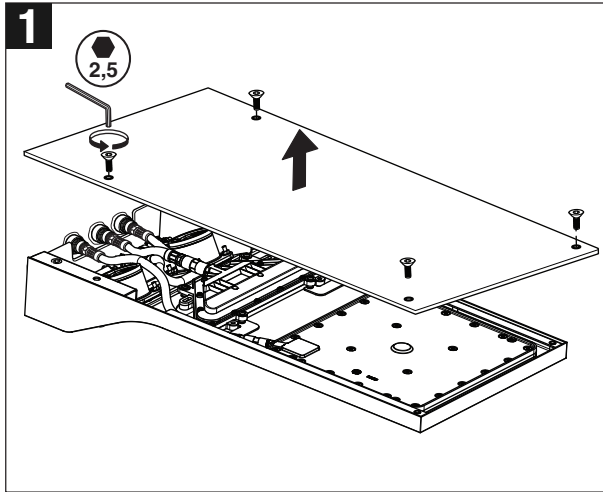

Cura e garanzia del prodotto | Maintenance and warranty of the product | Entretien et garantie du produit | Pflege-und Produktgarantie | Cuidado y garantía del producto |

IMPORTANTE: RICORDIAMO CHE LA GARANZIA NON COPRE I DANNI CAUSATI DAL DEPOSITO DI CALCARE O IMPURITA' O SE L'APPARECCHIO RISULTERA' AVER SUBITO TRATTAMENTI DIVERSI DA QUELLI DA NOI QUI SUGGERITI.

Per evitare danni al vostro bagno o all'apparecchiatura acquistata vi invitiamo ad osservare le seguenti raccomandazioni di utilizzo:

- Spurgare l'impianto prima di collegare l'apparecchio.
- Pulire periodicamente la fessura di erogazione acqua da eventuali depositi di calcare che potrebbero compromettere il corretto funzionamento.

Consiglio: L'installazione di un impianto di filtraggio e addolcitura delle acque migliora e prolunga la vita dei nostri apparecchi e dell'impianto stesso.

PULIZIA PARTI METALLICHE:

Per la semplice pulizia delle parti metalliche del prodotto è sufficiente usare un panno morbido e inumidito con acqua e sapone o un prodotto anticalcare. Per evitare la formazione di macchie, dovute alla presenza di calcio nell'acqua, si consiglia di asciugare con un panno dopo ogni uso.

Consiglio: Si prega di usare solo detersivi naturali a base di sapone evitando quelli contenenti alcool, acido cloridrico o acido fosforico, candeggina, cloro, ecc., e quelli contenenti polveri abrasive.

L'apparecchio è garantito **2 anni** contro difetti o vizi di fabbricazione.

La garanzia non copre danni causati da:

- Installazione e/o utilizzo diversi da quelli suggeriti dal manuale d'uso e manutenzione.
- Errata predisposizione e realizzazione dell'impianto idrico.
- La normale e fisiologica usura per utilizzo corretto.
- Danni causati da deposito di calcare o impurità.
- Impiego di materiali di pulizia diversi da quelli qui indicati.

IMPORTANT: PRIER DE NOTER QUE LA GARANTIE NE COUVRE PAS LES DOMMAGES CAUSÉS EN SUITE AU DÉPÔT DE CALCAIRE OU D'IMPURETÉS OU SI L'APPAREIL A EU DES TRAITEMENTS DIFFÉRENTS À CEUX QUE NOUS VOUS PROPOSONS CI-DESSOUS.

Afin d'éviter des dégâts dans la salles de bain ou à l'appareil acheté, nous vous invitons à suivre le mode d'emploi suivant:

- Purger l'installation hydraulique avant de connecter l'appareil.
- Nettoyer périodiquement la fente de la lame des éventuels dépôts de calcaires qui pourraient compromettre leur correct fonctionnement.

Conseil: L'installation d'une station de filtrage et d'adoucisseur d'eau améliore et allonge la durée de la vie de nos appareils et même de l'installation.

NETTOYAGE COMPOSANTS MÉTALLIQUES :

Il faut nettoyer les parties métalliques avec un chiffon souple et trempé avec du savon et de l'eau ou bien avec un produit anticalcaire. Afin d'éviter la formation des taches, déterminées par la présence de calcium dans l'eau, il faut essuyer et polir avec un chiffon souple après chaque usage.

Conseil: Prier de n'employer que des détergents simples, à base d'ingrédients naturels (savons) en évitant tous les produits qui contiennent de l'alcool, de l'acide chlorhydrique ou de l'acide phosphorique, de l'eau de Javel, chlore, etc., et ceux contenant de la poudre abrasive.

L'appareil est garantie par deux ans en cas de défauts et vice de fabrication.

La garantie ne couvre pas des dommages causés ensuite à:

- L'installation et/ou l'emploi divers de ceux qui sont écrits dans le mode d'emploi et l'entretien.
- L'erronée prédisposition et mise en place de l'installation hydraulique.
- La normale et physiologique usure à la suite du correct emploi.
- Les dommages causés par le dépôt de calcaire ou bien des impuretés.
- L'emploi des matériaux de nettoyage différents à ceux-ci recensés

IMPORTANTE: RECUERDE QUE LA GARANTÍA NO CUBRE DAÑOS CAUSADOS POR LA ACUMULACIÓN DE CAL O IMPUREZAS O SI EL APARATO SE HA SOMETIDO A UN TRATAMIENTO DISTINTO DE LOS SUGERIDOS POR NOSOTROS EN ESTE MANUAL.

Para evitar daños en su cuarto de baño o de los equipos adquiridos, tenga en cuenta las siguientes recomendaciones para su uso:

- Haga correr el agua de la instalación antes de conectar el aparato.
- Limpie periódicamente la ranura de la cascada para liberarla de los depósitos de caliza pueden evitar el correcto funcionamiento.

Consejo: La instalación de una planta de filtros y descalcificador mejora y prolonga la vida de nuestros aparatos y de la planta también.

LIMPIEZA DE LAS PIEZAS METÁLICAS:

Para la limpieza de piezas metálicas es suficiente utilizar un paño suave humedecido con agua y jabón o un producto antical. Para evitar manchas, debido a

IMPORTANT: WE REMIND YOU THAT THE WARRANTY DOES NOT COVER DAMAGES CAUSED BY DEPOSITS OF LIMESTONE OR IMPURITIES OR IF THE DEVICE HAS UNDERGONE DIFFERENT TREATMENTS FROM THOSE SUGGESTED HERE.

To avoid damages to your bathroom or to the purchased equipment, please observe the following recommendations for use:

- Clean the plumbing before connecting the device.
- Periodically clean the water blade to avoid any limestone deposits that could compromise the good functioning.

Advice: The installation of a filter and water-softener system improves and extends the life of the devices and of the plant itself.

CLEANING OF METAL PARTS:

For an easy cleaning of the metal parts of the product, simply use a soft cloth moistened in water and soap or an anti-limestone detergent.

To avoid spots caused by calcium in water, we advise drying with a cloth after each use.

Advice: Please use only natural soap-based detergents avoiding those with alcohol, hydrochloric acid or phosphoric acid, bleach, chlorine etc. and those containing abrasive powders.

The device is covered by **2 years** warranty against manufacturing defects.

The warranty does not cover damages caused by:

- Different installation and/or use from those suggested by the operating and maintenance manual.
- Incorrect preparation and implementation of the waterworks.
- The regular and physiological wear and tear for correct use.
- Damages caused by limestone deposits or impurities.

WICHTIG: BEDENKEN SIE, DASS DIE GARANTIE DECKT KEINE SCHÄDEN, DIE DURCH DIE KALKABLAGERUNG ODER VERUNREINIGUNGEN VERURSACHT SIND ODER WENN DAS GERÄT MEHRERE BEHANDLUNGEN UNTERZOGEN HAT, DIE ANDERS ALS WIR SCHLUGEN SIND.

Um Schäden an Ihrem Badezimmer oder gekauften Geräte zu vermeiden, beachten Sie bitte folgende Empfehlungen für die Verwendung:

- Putzen Sie der Anlage vor dem Anschluss des Gerätes.
- Regelmäßige Reinigung der Fallkante von eventuellen Kalkablagerungen, die den Betrieb stören können.

Tipp: Die Installierung von einer Filteranlage und einem Wasserenthärter verbessert und verlängert die Lebensdauer unserer Geräte und der Pflanze selbst.

REINIGUNG VON METALLTEILEN:

Zur einfachen Reinigung von Metallteilen ist ausreichend, um einen weichen Tuch mit Wasser und Seife oder einen Produkt gegen Kalk zu benutzen. Um die Färbung aufgrund der Anwesenheit von Kalk im Wasser zu vermeiden, sollten Sie mit einem Tuch nach jedem Gebrauch reinigen.

Tipp: Verwenden Sie bitte nur natürliche Seife-basierte Waschmittel und vermeiden solche mit Alkohol, Salzsäure oder Phosphorsäure, Bleichmittel, Chlor usw. und diese mit Scheuerpulver.

Das Gerät verfügt über eine **2-jährige** Garantie auf Herstellungsfehler.

Die Garantie deckt keine Schäden verursacht durch:

- Installation und / oder Benutzung die unterscheiden sich von denen von der Bedienungs- und Wartungsanleitung vorgeschlagen.
- Falsche Vorbereitung und Durchführung von Wasser-System.
- Normaler physiologischer Verschleiß für die ordnungsgemäße Verwendung.
- Schäden, die durch die Kalkablagerung oder Verunreinigungen verursacht sind.
- Einsatz von Reinigungsmitteln andere als die hier aufgeführten.

la presencia de cal en el agua, se recomienda limpiar con un paño después de cada uso.

Consejo: Utilice únicamente detergentes naturales a base de jabón detergente y evite los que contienen alcohol, ácido clorhídrico o ácido fosfórico, lejía, cloro, etc, así como productos abrasivos.

El producto tiene una garantía de **2 años** contra defectos de fabricación.

La garantía no cubre daños causados por:

- La instalación y / o el uso diferente de lo sugerido por el manual de empleo y mantenimiento.
- La disposición y la realización incorrecta del circuito hidráulico.
- El desgaste natural con un uso correcto.
- Los daños causados por la acumulación de cal o impurezas.
- El uso de materiales de limpieza que no sean las sugeridas en este manual.